

INTELLIGENT GROUND VEHICLE

Background

As part of the UC Irvine Intelligent Ground Vehicle team, students will be in charge of designing and testing a vehicle that will be able to autonomously navigate through an obstacle course for participation in the Intelligent Ground Vehicle Competition (IGVC). The IGVC offers a design experience that is multidisciplinary, theory-based, hands-on, team implemented, outcome assessed, and based on product realization. It encompasses the very latest technologies impacting industrial development including intelligent transportation systems, military applications, and manufacturing. The deadline of the Intelligent Ground Vehicle Competition creates a real-world constraint that provides potential winning recognition and financial gain.

Goals and Objectives

To design an autonomous ground vehicle that can compete in the Autonav and Interoperability Challenge of the IGV competition.

- Objective:
- Maintain average velocity of 1 - 5 mph
 - Dodge obstacles such as potholes, barrels, and trees
 - Follow laid out track
 - Climb incline ramps
 - Move accordingly to location-specific movement commands

Budget

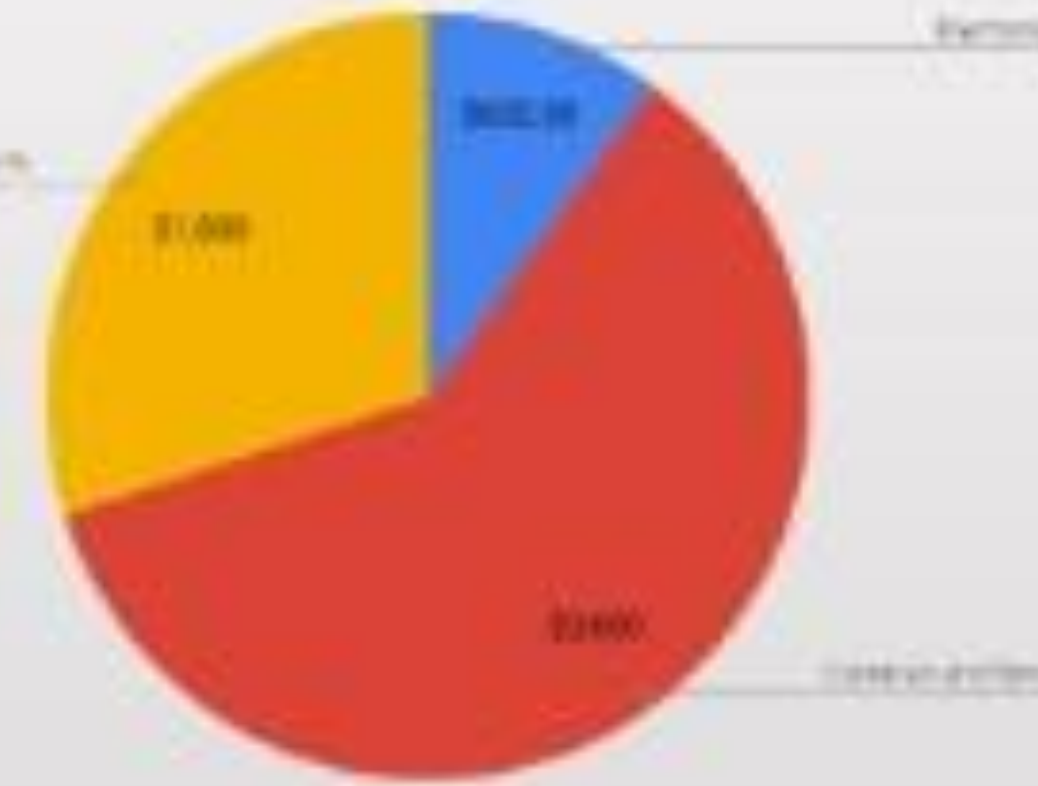

Timeline



Team Members



Advisor

Prof. David Reinkensmeyer
dreinken@uci.edu

Contact

Project Lead
Tony Moc
tmoc@uci.edu

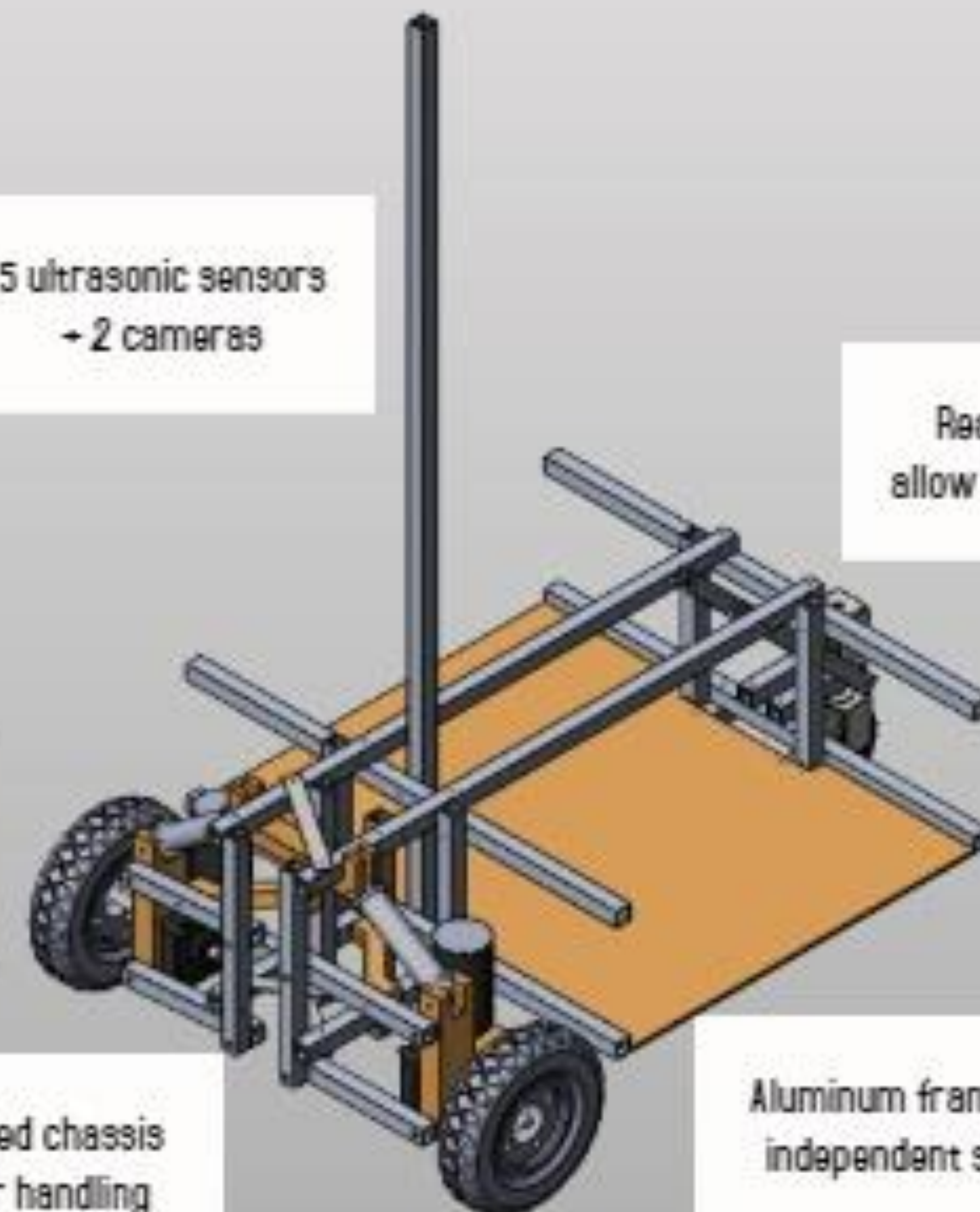

5 ultrasonic sensors
+ 2 cameras

Rear caster wheel to
allow for 0 radius steering

Mechanical and Wireless
E-Stops for safety

Differential Steering for
simple and fast steering

Front loaded chassis
for better handling

Aluminum frame with front-wheel
independent suspension system