



Dynamic Electric Differential

Lucas Juttner (ljuttner@uci.edu), Mario Medina (mmedinap@uci.edu), Joshua Miller (jemille2@uci.edu), Leslie Uribe (liuribe@uci.edu)

Professor Quoc-Viet Dang

Fall 2019 - Department of Electrical Engineering and Computer Science

Background

Electric vehicles with two independent motors have the capability to offer better performance results than typical internal combustion vehicles, via electronic control algorithms such as torque vectoring [1,2]. In addition, electric vehicles are gaining in popularity and could potentially gain majority market of car sales in the future.

Project Goals

The goals of our project is to design, develop, and test a functional torque vectoring algorithm to increase the performance of electric vehicles which utilize two, independent rear motors [3,4].

- Develop algorithm on microcontroller with a simple ramp function to confirm increase in performance
- Create a testbed using two brushless motors
- Modify the algorithm to use real time sensors maximizing the performance of the car

Materials Needed

Hardware

- Two motors with variable speed potential
- A microcontroller
- Two potentiometers to simulate acceleration and steering angle
- Sensors to measure wheel speed, acceleration, and g-force (hall-effect sensor, accelerometer, and gyroscope)

Software

- The software flow will consist of obtaining the data from the potentiometers, and using equations to alter the torque signal sent to the motors when the steering angle indicates the vehicle is in a turn

Prototype

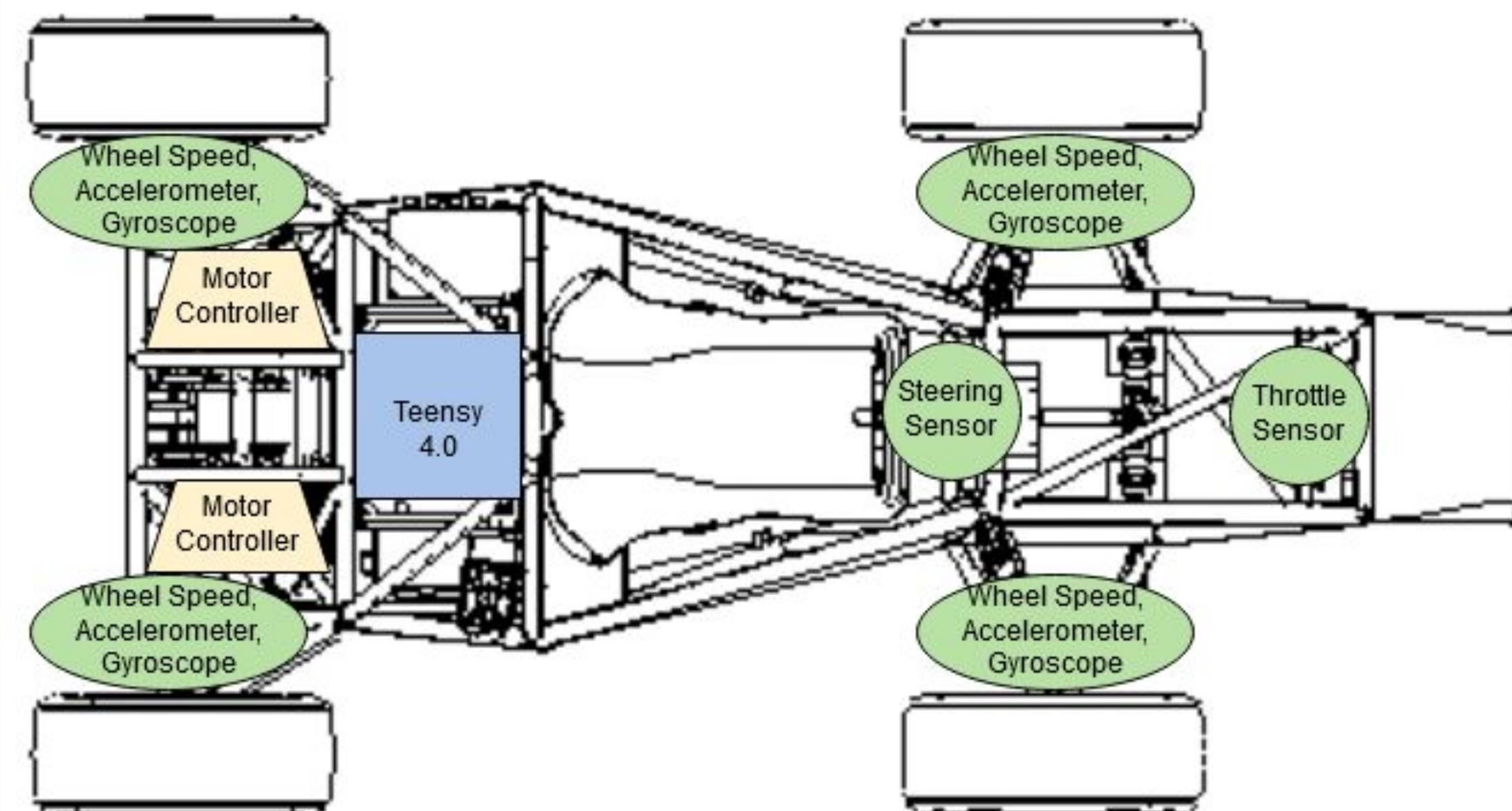

Figure 1: Relative position of sensors and components on an FSAE electric vehicle

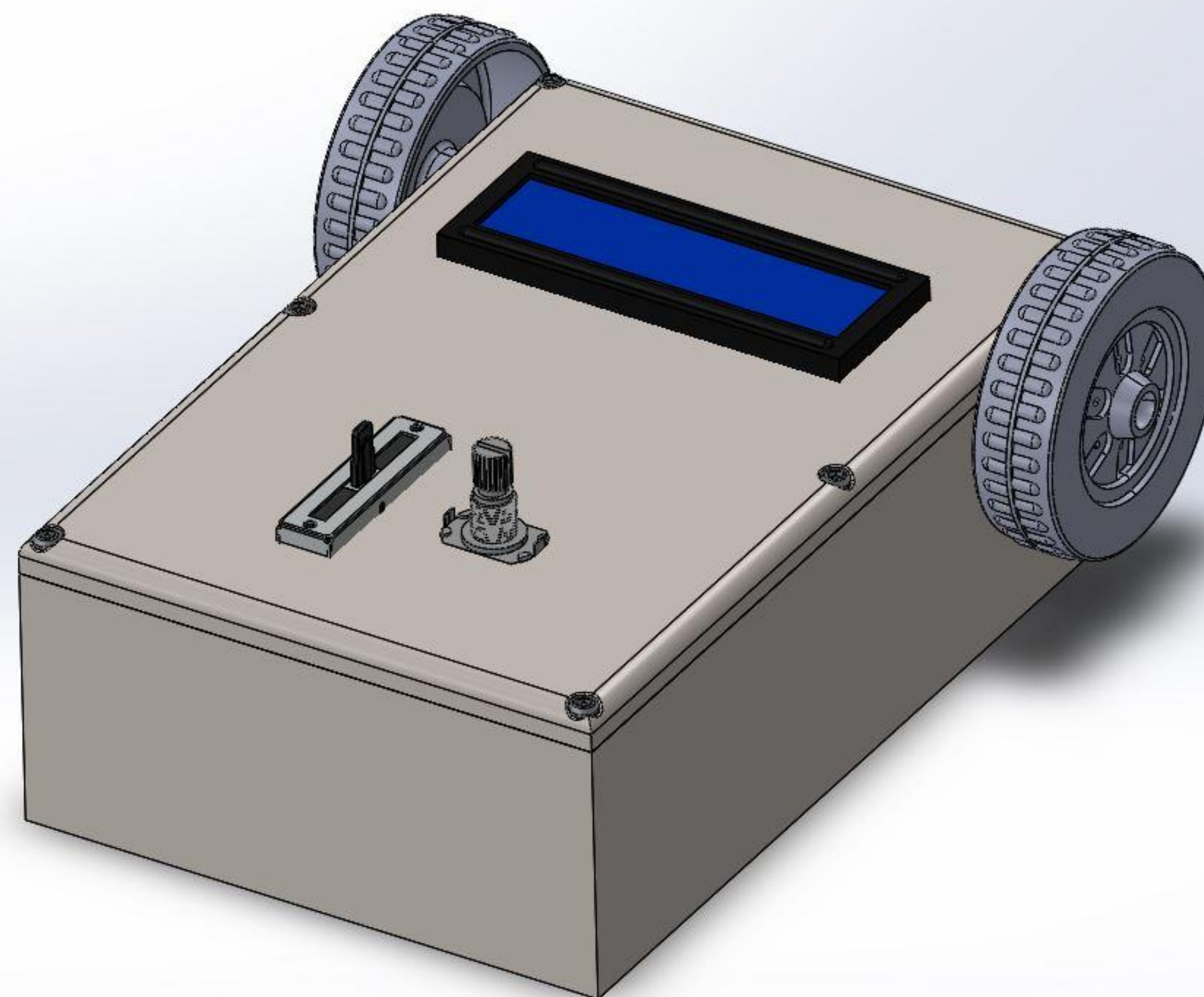

Figure 2: Prototype to test our Torque Vectoring Algorithm

Milestones

- 10/28/2019 - Working Initial Testbench
- 11/4/2019 - Basic Torque Vectoring Algorithm Implemented
- 11/11/2019 - Performance of Basic Algorithm Evaluated
- 11/18/2019 - Advanced Torque Vectoring Algorithm Designed
- 12/2/2019 - Advanced Torque Vectoring Algorithm Implemented

Current State

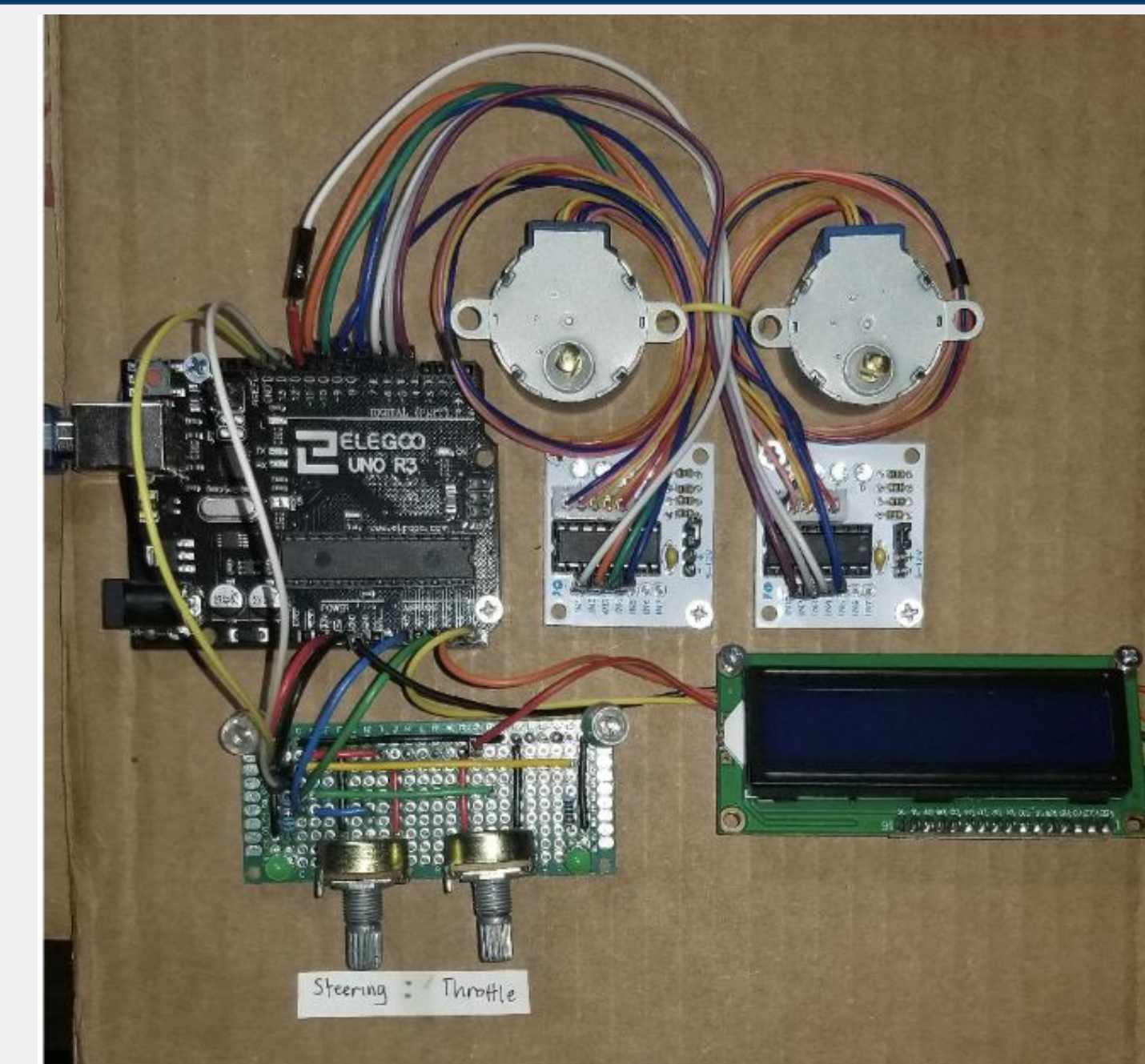

Figure 3: Hardware testbench for verification of basic torque vectoring algorithm

References

1. Brown, Lochlan. "Improving Performance Using Torque Vectoring on an Electric All-Wheel-Drive Formula SAE Race Car." *The University of Western Australia*, May 2013
2. Gatta, Nick. "Formula SAE Electric Drive Control." *The University of Akron*, Nov. 2012
3. Nguyen Huu, P. (2014). Electronic Differentials for High-Performance Electric Racecars. *UC Irvine*. ProQuest ID: NguyenHuu_uci_0030D_13050. Merritt ID: ark:/13030/m5st9436. Retrieved from <https://escholarship.org/uc/item/7997f1xq>
4. Tukaram Pawar, Vikas. "Active Torque Vectoring for All Wheel Drive FSAE Electric Car." *The University of Texas at Arlington*, Aug. 2016